

Precast Concrete Manhole (48" ID) Sanitary Sewer (Monolithic Base & Flat Top)

Openings for inlets & outlets are made 4 inches larger in diameter than the outside diameter of the pipe & are located as required per plans.

SPECIFICATIONS:

ASTM C478
Concrete: 4000 PSI (Min.)
Approx. Wt./LinFt: 870 Lbs.
Joint O-Ring Gasket

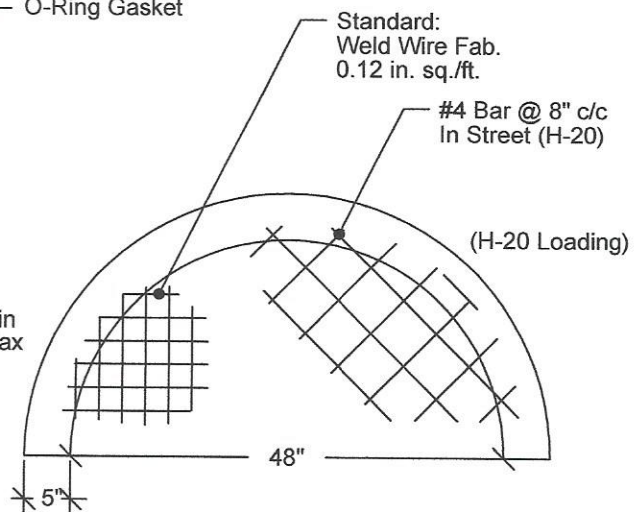
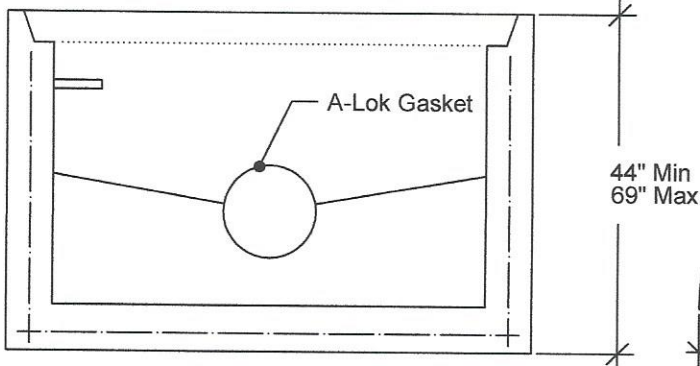
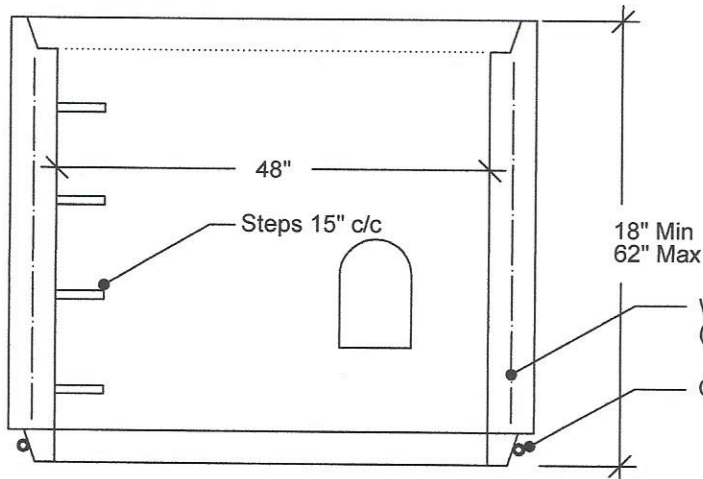
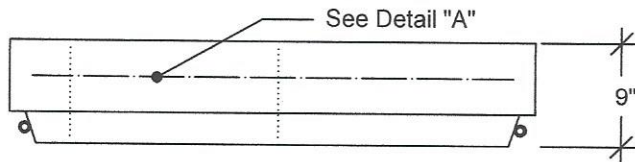
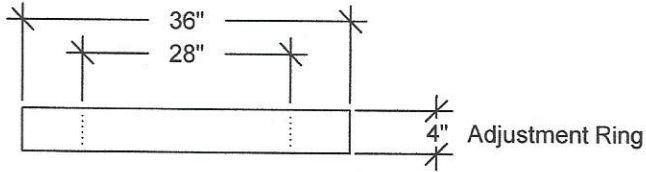

Trough in invert to be left 1 in below Flow.
Feathered to flow by contractor.

DETAIL "A"

2100 NORTH 161ST E. AVE.
TULSA, OKLAHOMA 74116



WWW.GNCCONCRETEPRODUCTS.COM

OFC: (918) 438-1182
FAX: (918) 438-1185