

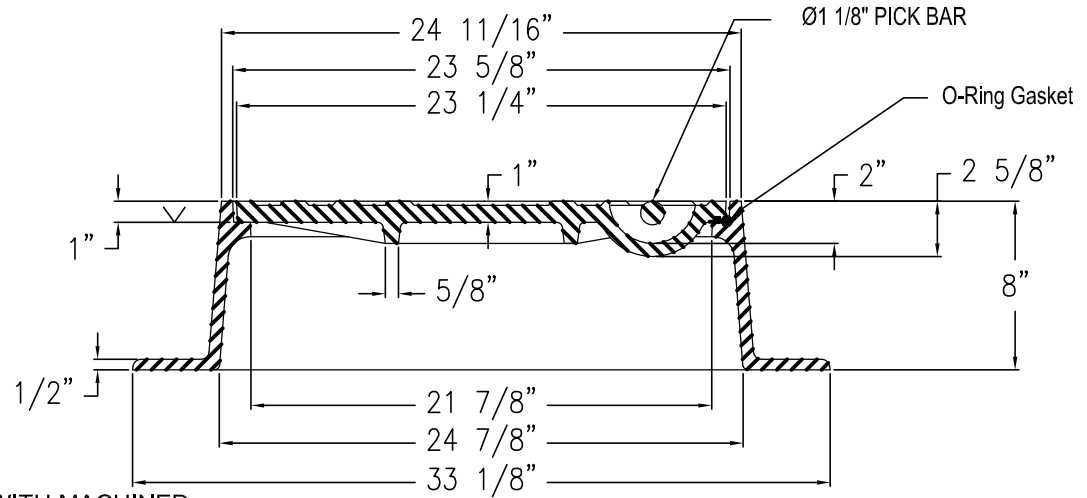

Manhole Ring & Cover #1265

Revised 4/28/00 KRH
1 ADDED MADE IN USA, COMPONENT #

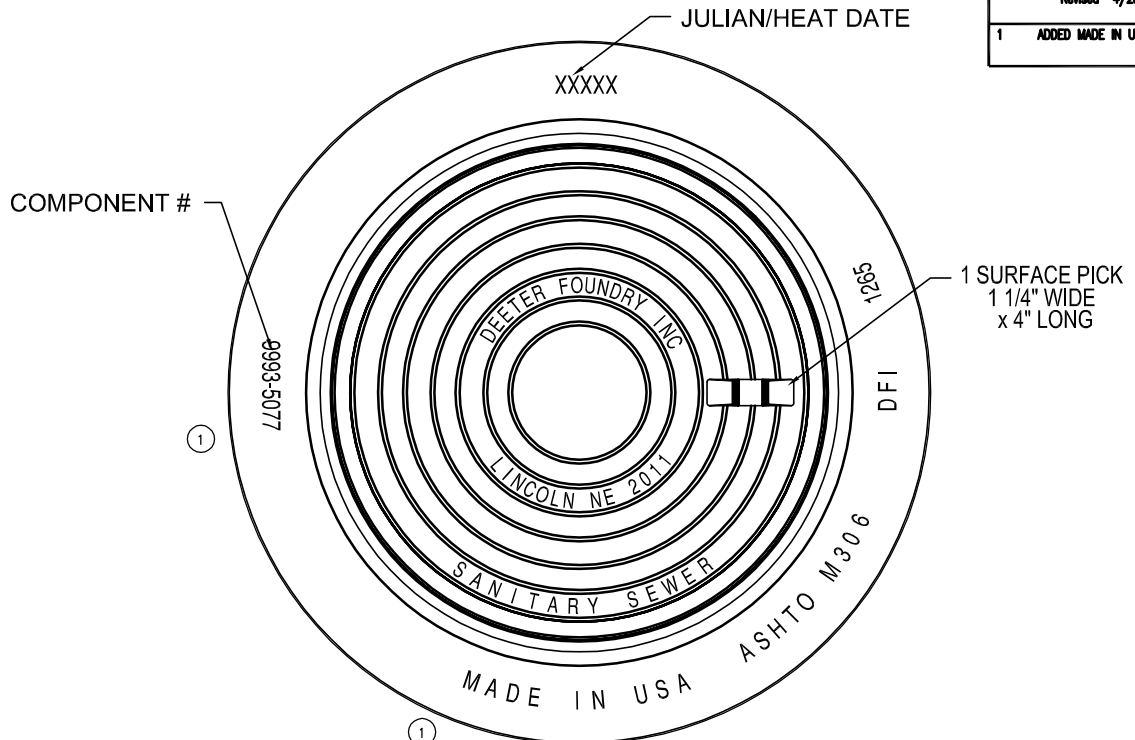

- NOTE:
1. FURNISHED WITH MACHINED HORIZONTAL BEARING SURFACES.
 2. FURNISHED WITH T-GASKET.

MATERIAL: CAST GRAY IRON ASTM A-48, CLASS 35B
FINISH: NO PAINT
WEIGHT: FRAME 160 LBS.
WEIGHT: COVER 110 LBS.

 Deeter Foundry, Inc. 5945 NORTH 70th STREET LINCOLN, NEBRASKA 68529		
# 1265SS MANHOLE RING & COVER		
Date: 2 JUN 11	Drawn by: KRH	Scale: 1/8
DRAWING NO. 01-M1265-01	Revised by:	Date:



2100 NORTH 161ST E. AVE.
 TULSA, OKLAHOMA 74116 WWW.GNCCONCRETEPRODUCTS.COM

OFC: (918) 438-1182
 FAX: (918) 438-1185